

1650CT / 1650 / 1650CTSN / 1650SN / 1650DR

“COBRAPRESS”

PRESS FITTINGS

FOR “AL-COBRAPEX” MULTILAYER PIPE

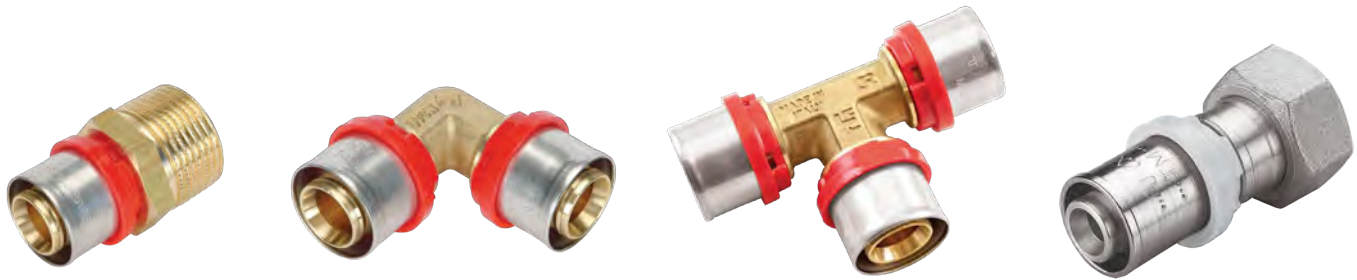

DESCRIPTION

Tiemme press fittings for multilayer pipes adapt to any type of heating/cooling and sanitation system, with application in residential, commercial, industrial and agricultural sectors and, in general, with any kind of non-corrosive fluid.

These fittings are used to make irreversible joints and so **can be used for chased installation in compliance with current standards.**

These press fittings are characterised by their sealing mechanism which is created by mechanical deformation of the external stainless-steel bush.

This deformation is carried out using a specific tool equipped with suitable steel crimpers; this ensures that the clamping pressure is always the same and is at an optimal level for all the fittings, thus increasing the reliability of the joint.

Tiemme press fittings are also characterised by the presence of a polymer ring which performs three very important functions:

- The first, since it is a plastic material, is its dielectric function, i.e. it prevents the internal aluminium layer of the pipe from coming into contact with the body of the fitting (in brass) and triggering the **galvanic corrosion** process, caused by stray currents (to learn more see the "INFORMATION FROM TIEMME" section of this technical data sheet).

- The second function, also of fundamental importance, is that which allows the installer to visually and easily check that the pipe is correctly inserted into the fitting.

- The third function facilitates the correct positioning of the fitting to be pressed inside the "TH" profile crimping tool.

This quickly and easily verifiable possibility, guarantees a peace of mind during installation that is rare in other types of fittings.

ADVANTAGES / STRENGTHS

- Double gasket and anti-slip profile: to guarantee perfect sealing.
- Stainless-steel pipe clamping bush: high resistance to corrosion.
- Plastic ring nut with 4 viewing windows: makes it possible to check the correct insertion of the pipe.
- Multi-crimping fittings (TH, U, H, B, RF, Tiemme customised TH profile).
- Can be chase installed.
- System complete with dedicated AL-COBRAPEX pipe and tools (shears, calibrating/deburring tools, pressers, crimpers...).
- Wide range available, for every installation need:
 - Connection diameters from 14 to 90 mm.
 - Compact series / Standard series.
 - Series with tin-plated finish to offer a corrosion-resistant, attractive look in chased systems.
 - Series made in CW602N dezincification-proof brass: this alloy's property prevents the break-up of the zinc contained in it, for greater structural reliability of the fitting over time, while preventing the leaching of external metals into the water being conveyed. **RINA certified series, also suitable for applications in the naval sector.**

PRODUCTION RANGE

Press fittings for multilayer pipe are available in a wide range of sizes (from \varnothing 14 to \varnothing 90 mm), different shapes (straight, curved, T-shaped etc.), with different types of connections (female threaded connections, Male threaded connections, intermediate press connections etc...), and in different versions (compact version, standard version, version with tin-plated finish and a version made in CW602N dezincification-proof brass), to meet all kinds of system requirement.

See the MASTER catalogue for the full range.

CONSTRUCTION SPECIFICATIONS

1650CT series (compact version)

- (1) Fitting body: CW617N Brass
- (2) Ring nut / dielectric and viewing ring: PA
- (3) O-ring seal: EPDM
- (4) Clamping bush: AISI 304 stainless steel
- Threads: F ISO 228
M ISO 228 / M ISO 7/1 (EN 10226) R conical

1650 series (standard version)

- (1) Fitting body: CW617N Brass
- (2) Ring nut / dielectric and viewing ring: PA
- (3) O-ring seal: EPDM
- (4) Clamping bush: AISI 304 stainless steel
- Threads: F ISO 7/1 (EN 10226) RP cylindrical
M ISO 7/1 (EN 10226) R conical

1650CTSN series (compact version / tin-plated finish)

- (1) Fitting body: Tin-plated CW617N Brass
- (2) Ring nut / dielectric and viewing ring: PA
- (3) O-ring seal: EPDM
- (4) Clamping bush: AISI 304 stainless steel
- Threads: F ISO 228
M ISO 228 / M ISO 7/1 (EN 10226) R conical

1650SN series (standard version / tin-plated finish)

- (1) Fitting body: Tin-plated CW617N Brass
- (2) Ring nut / dielectric and viewing ring: PA
- (3) O-ring seal: EPDM
- (4) Clamping bush: AISI 304 stainless steel
- Threads: F ISO 7/1 (EN 10226) RP cylindrical
M ISO 7/1 (EN 10226) R conical

1650DR series (version made of CW602N anti-dezincification brass)

- (1) Fitting body: CW602N anti-dezincification brass
- (2) Ring nut / dielectric and viewing ring: PA
- (3) O-ring seal: EPDM
- (4) Clamping bush: AISI 304 stainless steel
- Threads: F ISO 7/1 (EN 10226) RP cylindrical
M ISO 7/1 (EN 10226) R conical

TECHNICAL SPECIFICATIONS

- Maximum working temperature: + 95 °C
- Minimum working temperature: - 20 °C (provided the fluid remains in the liquid phase)
- Maximum working pressure: 10 bar (relative to the AL-COBRAPEX multilayer pipe)
- Fluid compatibility: Drinking water, water and glycol solutions (maximum percentage of glycol 30%)
non-corrosive fluids *

* To check compatibility with fluids or other substances not listed, contact the Tiemme Technical Dept.

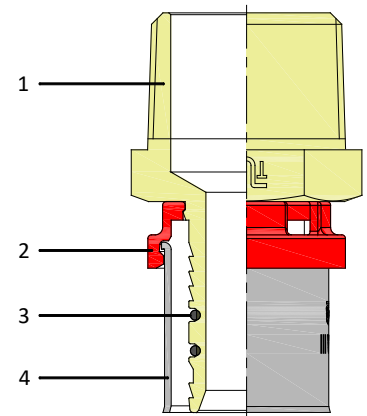

INSTRUCTIONS FOR CORRECT ASSEMBLY

To obtain a perfect join between fitting/pipe, some simple but important operations must be carried out:

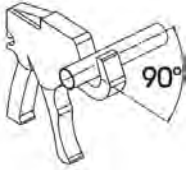
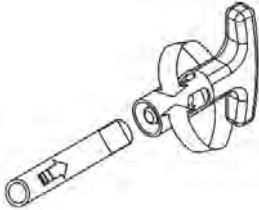
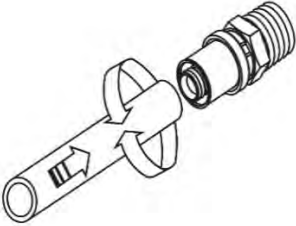
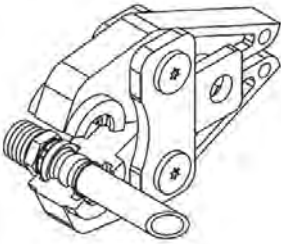
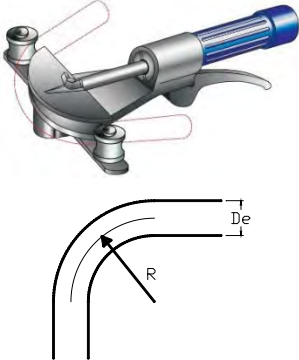
	<p>Cutting the pipe: The pipe must be cut perpendicular to its axis. The use of hacksaws or angle grinders must be avoided as they could deform the pipe. Recommended tools: Up to \varnothing 32 mm Art. 1495 - over \varnothing 32 mm Art. 1683</p>																																																																					
	<p>Pipe calibration and flaring: Restore the shape of the pipe using the appropriate calibrator. Take care when carrying out pipe calibration and deburring; the proper tools must be used. Any burr residue could damage the O-rings. The calibrating/deburring tool should be inserted into the pipe and then turned clockwise. Recommended tools: Complete case Art. 1498SET</p>																																																																					
	<p>Connecting the pipe to the fitting: Insert the pipe into the fitting until it encounters the stop (check through the 4 "windows" on the ring); take care not to move the O-ring seals out of their seat. Connection will be easier if the pipe is lubricated with silicone oil or water. For domestic water distribution applications, make sure that the silicone oil used is suitable for food application. The use of a different lubricant could damage the fitting's seals. Make sure that the oil used is compatible with the construction materials of the fitting.</p>																																																																					
	<p>Pressing: Before pressing the fitting, check that the ring nut/bushing is correctly assembled in the specific seat made in the brass fitting, if not, the ring nut/bushing should be repositioned. It is also advisable to check that the pipe is placed correctly in contact with the plastic ring nut to ensure that the internal aluminium layer does not encounter the covering material. Position the fitting correctly onto the crimper of the specific tool (pressing tool). Ensure that the jaws are not particularly worn. Press the fitting. Make sure that the crimper fully closes. Tiemme fittings are designed and tested to be pressed indifferently with 6 different profiles: Tiemme customised TH - TH - U - H - B - RF For further details, see the "MULTI-CRIMP FITTINGS" section of this technical data sheet.</p>																																																																					
	<p>Bending: The pipe can be bent by hand or using the specific tools, depending on the radius required. The table below provides an indication of the minimum bending radii permitted:</p> <table border="1" data-bbox="467 1429 1445 1839"> <thead> <tr> <th rowspan="2">\varnothing external pipe (mm)</th> <th colspan="4">Bending radius R (mm)</th> </tr> <tr> <th>Manual</th> <th>Manual with internal spring</th> <th>Manual with external spring</th> <th>Mechanical</th> </tr> </thead> <tbody> <tr><td>14</td><td>70</td><td>56</td><td>56</td><td>41</td></tr> <tr><td>16</td><td>80</td><td>64</td><td>64</td><td>49</td></tr> <tr><td>18</td><td>90</td><td>72</td><td>72</td><td>65</td></tr> <tr><td>20</td><td>100</td><td>80</td><td>80</td><td>80</td></tr> <tr><td>25</td><td>130</td><td>100</td><td>-</td><td>90</td></tr> <tr><td>26</td><td>130</td><td>100</td><td>100</td><td>90</td></tr> <tr><td>32</td><td>160</td><td>-</td><td>-</td><td>120</td></tr> <tr><td>40</td><td>-</td><td>-</td><td>-</td><td>150</td></tr> <tr><td>50</td><td>-</td><td>-</td><td>-</td><td>190</td></tr> <tr><td>63</td><td>-</td><td>-</td><td>-</td><td>240</td></tr> <tr><td>75</td><td>-</td><td>-</td><td>-</td><td>320</td></tr> <tr><td>90</td><td>-</td><td>-</td><td>-</td><td>530</td></tr> </tbody> </table> <p>Recommended tools: Pipe bending spring Art. 1497 – Art. 1497EST / Pipe-bender Art. 1684</p>	\varnothing external pipe (mm)	Bending radius R (mm)				Manual	Manual with internal spring	Manual with external spring	Mechanical	14	70	56	56	41	16	80	64	64	49	18	90	72	72	65	20	100	80	80	80	25	130	100	-	90	26	130	100	100	90	32	160	-	-	120	40	-	-	-	150	50	-	-	-	190	63	-	-	-	240	75	-	-	-	320	90	-	-	-	530
\varnothing external pipe (mm)	Bending radius R (mm)																																																																					
	Manual	Manual with internal spring	Manual with external spring	Mechanical																																																																		
14	70	56	56	41																																																																		
16	80	64	64	49																																																																		
18	90	72	72	65																																																																		
20	100	80	80	80																																																																		
25	130	100	-	90																																																																		
26	130	100	100	90																																																																		
32	160	-	-	120																																																																		
40	-	-	-	150																																																																		
50	-	-	-	190																																																																		
63	-	-	-	240																																																																		
75	-	-	-	320																																																																		
90	-	-	-	530																																																																		

IMPORTANT: Carrying out the following operations incorrectly, may compromise the tightness of the joint.

TIEMME RACCORDERIE S.p.A. will accept no responsibility for breakages and/or accidents resulting from failure to comply with these indications and from improper use of the system. The information shown does not exempt the user from scrupulously following current regulations and good technical standards.

NEVER:

- Use incompatible or harmful substances.
- Allow direct contact of the fittings with cast concrete during installation: protect with suitable means.
- Connect the multilayer pipe directly to boilers, water heaters or any other source of heat

We recommended using a joint with a metal pipe for a length of at least one metre to protect the multilayer pipe from any malfunction of heat generators

SOME POSSIBLE CAUSES OF LEAKS:

- Pressing performed with excessively worn crimpers.
- Failure to fully close the crimper.
- Incorrect positioning of the fitting on the crimper at the time of pressing.
- Breakage or leakage of the O-rings due to pipes not being properly cut, calibrated and deburred.
- Connection with incompatible products.
- Incompatible fluids.
- Excessive use of sealants (e.g. hemp, PTFE tape etc...) on male/female threads could generate tension in the fittings.
- Freezing of the system or excessive internal pressure
- Storage of materials in unsuitable environments.
- Unpredictable external causes, such as accidental impacts or inappropriate movements.

MULTI-CRIMP FITTINGS

Tiemme fittings are designed and tested to be pressed indifferently with 6 different profiles: **Tiemme customised TH - TH - U - H - B - RF.**

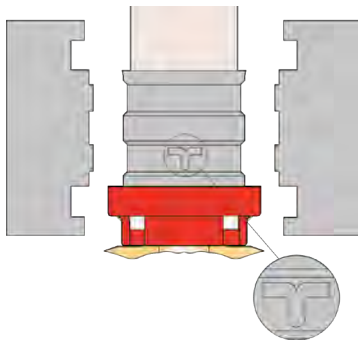

Logo illustration  imprinted on the bush after pressing performed using a TH profile crimping tool – **Tiemme customised**

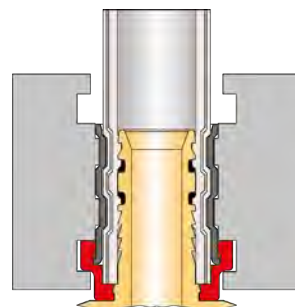

Crimping profile: **Tiemme customised TH**
Crimping profile: **TH**

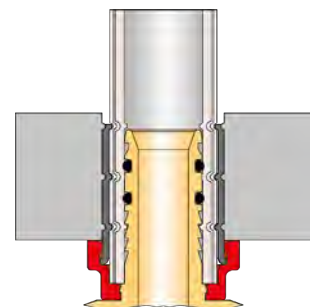

Crimping profile: **U**

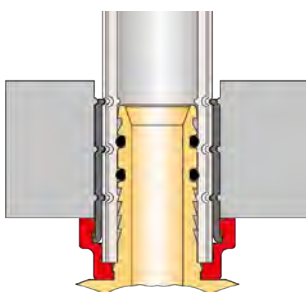

Crimping profile: **H**

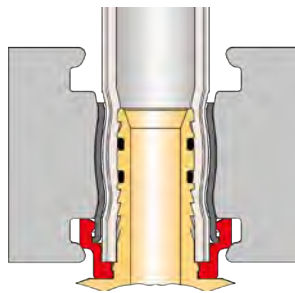

Crimping profile: **B**

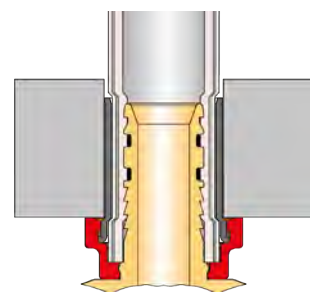

Crimping profile: **RF**

Below is a table showing the compatibility of the different crimping profiles depending on the diameter of the pipe:

Crimping profile	Ø external pipe (mm)											
	14	16	18	20	25	26	32	40	50	63	75	90
TH	X	X	X	X	X	X	X	X	X	X	X	-
U	X	X	X	X	X	-	X	-	-	-	-	X
H	X	X	X	X	X	X	X	-	-	-	-	-
B	X	X	X	X	-	X	X	-	-	-	-	-
RF	X	X	X	X	-	-	-	-	-	-	-	-

(X) Compatible

(-) Non-compatible

LOCALISED PRESSURE DROPS

The values of the pressure drops of the fittings, expressed in **equivalent metres of pipe (L_{eq})**, are shown below, i.e. the localised pressure drops of the fittings are expressed in an assumed length of the network (AL-COBRAPEX pipe) which determines the actual resistance value.

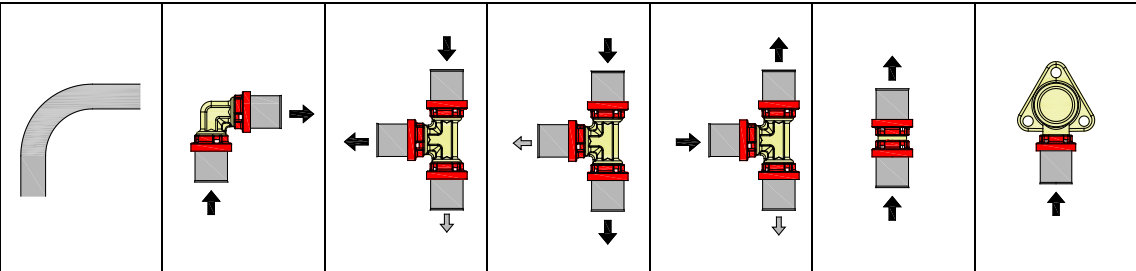
AL-COBRAPEX pipe	FLUID SPEED (m/s)							
		Values in equivalent metres of pipe (L _{eq})						
∅ 14x2	0.5	0.29	1.23	1.23	0.44	1.28	0.29	1.23
	0.8	0.32	1.33	1.33	0.48	1.39	0.32	1.33
	1	0.33	1.39	1.39	0.50	1.44	0.33	1.39
	2	0.41	1.72	1.72	0.62	1.79	0.41	1.72
∅ 16x2	0.5	0.31	1.16	1.25	0.38	1.31	0.31	1.16
	0.8	0.35	1.29	1.39	0.42	1.46	0.35	1.23
	1	0.36	1.32	1.43	0.43	1.50	0.36	1.32
	2	0.43	1.57	1.70	0.51	1.79	0.43	1.57
∅ 16x2,25	0.5	0.31	1.16	1.21	0.38	1.28	0.31	1.16
	0.8	0.35	1.33	1.40	0.43	1.47	0.35	1.33
	1	0.35	1.33	1.40	0.43	1.47	0.35	1.33
	2	0.44	1.67	1.75	0.54	1.83	0.44	1.68
∅ 18x2	0.5	0.30	1.21	1.25	0.34	1.33	0.23	1.21
	0.8	0.34	1.37	1.41	0.38	1.49	0.26	1.37
	1	0.36	1.46	1.50	0.40	1.59	0.27	1.46
	2	0.41	1.64	1.69	0.46	1.80	0.31	1.64
∅ 20x2	0.5	0.31	1.32	1.32	0.40	1.40	0.31	1.32
	0.8	0.36	1.52	1.52	0.46	1.63	0.36	1.52
	1	0.37	1.58	1.58	0.47	1.68	0.37	1.58
	2	0.44	1.88	1.88	0.56	2.00	0.44	1.88
∅ 20x2,5	0.5	0.31	1.27	1.29	0.37	1.37	0.29	1.27
	0.8	0.35	1.46	1.48	0.42	1.58	0.33	1.46
	1	0.38	1.55	1.58	0.45	1.68	0.35	1.55
	2	0.42	1.72	1.75	0.50	1.86	0.39	1.72
∅ 25x2,5	0.5	0.29	1.40	1.45	0.41	1.63	0.29	-
	0.8	0.33	1.60	1.67	0.47	1.87	0.33	-
	1	0.35	1.69	1.76	0.49	1.97	0.35	-
	2	0.40	1.92	2.00	0.56	2.24	0.40	-
∅ 26x3	0.5	0.29	1.40	1.45	0.41	1.63	0.29	-
	0.8	0.33	1.60	1.67	0.47	1.87	0.33	-
	1	0.35	1.69	1.76	0.49	1.97	0.35	-
	2	0.40	1.92	2.00	0.56	2.24	0.40	-
∅ 32x3	0.5	0.23	1.56	1.56	0.39	1.56	0.31	-
	0.8	0.27	1.83	1.83	0.46	1.83	0.37	-
	1	0.29	1.96	1.96	0.49	1.96	0.39	-
	2	0.33	2.22	2.22	0.56	2.22	0.44	-
∅ 40x3,5	0.5	0.27	1.63	2.07	0.44	2.17	0.33	-
	0.8	0.31	1.85	2.34	0.49	2.46	0.37	-
	1	0.33	1.97	2.50	0.53	2.63	0.40	-
	2	0.39	2.31	2.92	0.62	3.08	0.46	-
∅ 50x4	0.5	0.23	2.13	2.29	0.46	2.44	0.31	-
	0.8	0.26	2.42	2.60	0.52	2.77	0.35	-
	1	0.27	2.50	2.68	0.54	2.86	0.36	-
	2	0.31	2.87	3.08	0.62	3.28	0.41	-
∅ 63x4,5	0.5	0.21	2.50	2.92	0.63	3.13	0.42	-
	0.8	0.21	2.56	2.99	0.64	3.20	0.43	-
	1	0.24	2.86	3.33	0.71	3.57	0.48	-
	2	0.28	3.38	3.94	0.85	4.23	0.56	-

1650.W_Rev.P_04/2023 - TIEMME RACCORDERIE S.p.A. reserves the right to make changes at any time without notice. No form of reproduction is permitted, unless authorised

Ø 75x5	0.5	0.13	2.93	3.19	0.67	3.46	0.30	-
	0.8	0.14	3.06	3.34	0.70	3.62	0.30	-
	1	0.15	3.33	3.64	0.76	3.94	0.30	-
	2	0.17	3.83	4.17	0.87	4.52	0.35	-
Ø 90x7	0.5	0.00	3.21	3.53	0.64	3.85	0.30	-
	0.8	0.00	3.56	3.91	0.71	4.27	0.40	-
	1	0.00	3.57	3.93	0.71	4.29	0.36	-
	2	0.10	4.21	4.63	0.84	5.05	0.42	-

Speed 0.5 - 0.8 m/s: Heating application field

Speed 1 - 2 m/s: Domestic hot water application field

Alternatively, in the case of more complex sizing processes, the pressure drop values can be calculated using the following formula:

$$\Delta p = k * 0,005 * \rho * v^2$$

where:

Δp = Localized pressure drop (mbar)

k = Loss factor







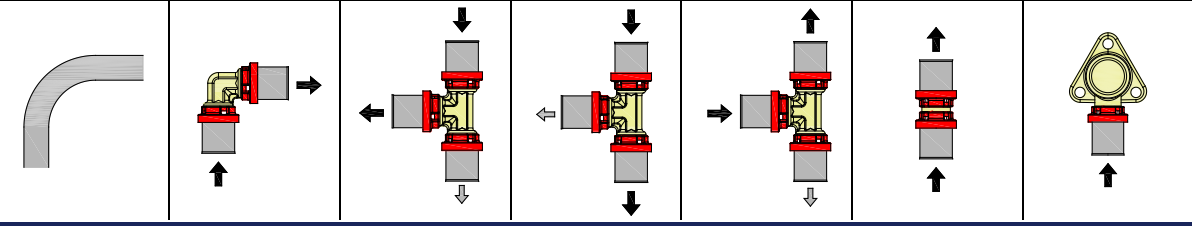



ρ = Fluid density (kg/m³)

v = Fluid speed (m/s)

The value of loss factor k is shown below

AL-COBRAPEX pipe								
	Loss factor k							
Ø 14	1.2	5.0	5.0	1.8	5.2	1.2	5.0	
Ø 16x2	1.0	3.7	4.0	1.2	4.2	1.0	3.7	
Ø 16x2,25	1.05	4.0	4.2	1.3	4.4	1.05	4.0	
Ø 18	0.8	3.2	3.3	0.9	3.5	0.6	3.2	
Ø 20x2	0.7	3.0	3.0	0.9	3.2	0.7	3.0	
Ø 20x2,5	0.75	3.1	3.15	0.9	3.35	0.7	3.1	
Ø 25	0.5	2.4	2.5	0.7	2.8	0.5	-	
Ø 26	0.5	2.4	2.5	0.7	2.8	0.5	-	
Ø 32	0.3	2.0	2.0	0.5	2.0	0.4	-	
Ø 40	0.25	1.5	1.9	0.4	2.0	0.3	-	
Ø 50	0.15	1.4	1.5	0.3	1.6	0.2	-	
Ø 63	0.1	1.2	1.4	0.3	1.5	0.2	-	
Ø 75	0.05	1.1	1.2	0.25	1.3	0.1	-	
Ø 90	0.0	1.0	1.1	0.2	1.2	0.1	-	

MAIN ACCESSORIES OF THE SYSTEM

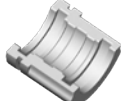
 <p>Art. 0600 AL-COBRAPEX Multilayer pipe</p>	 <p>Art. 1699 Stainless-steel bush assembly tool</p>	 <p>Art. 1497 / 1497EST Pipe-bending spring</p>	 <p>Art. 1684 Pipe-bender.</p>
 <p>Art. 1498SET Case with calibrating/deburring set.</p>	 <p>Art. 1498UM Calibrating/deburring tools with fixed handle.</p>	 <p>Art. 1498MT Interchangeable T-handle.</p>	 <p>Art. 1498US Interchangeable calibrating/deburring tools.</p>
 <p>Art. 1695TM01 - 1695TM03 Battery operated pressing tool.</p>	 <p>Art. 1685M Manual pressing tool.</p>	 <p>Art. 1681 - 1681 MINI Profile crimping tool Tiemme customised TH.</p>	 <p>Art. 1685US Insert for manual pressing tool. TH profile.</p>

See the product catalogue for order codes / further details.

INFORMATION FROM TIEMME

GALVANIC CORROSION OR "BATTERY EFFECT":

The phenomenon of galvanic corrosion occurs when two materials, with a different noble value, are placed in direct contact. A flow of electrons is generated from the less noble material, which oxidises, towards the more noble material which has greater potential. Less noble materials tend to corrode compared to the more noble materials, so putting a less noble metal into direct contact with a more noble metal will lead to the less noble metal corroding (acting as an anode) and corrosion will be accelerated.

The use of Tiemme press fittings guarantees that this phenomenon will not occur.

In fact, the internal aluminium layer of the pipe does not encounter the fitting (made of brass), as it is separated from the dielectric cap of the actual fitting.

ITEM SPECIFICATIONS

1650CT Series

Compact press fitting for "AL-COBRAPEX" multilayer pipe, made up of: CW617N brass body, PA ring nut / dielectric and viewer ring, EPDM O-ring seal, clamping bush in AISI 304 stainless steel, ISO 228 / ISO 7/1 (EN 10226) threads.

Maximum working temperature: + 95 °C. Minimum working temperature: - 20 °C (provided the fluid remains in the liquid phase). Maximum working pressure: 10 bar (relative to the AL-COBRAPEX multilayer pipe).

Fluid compatibility: drinking water, water and glycol solutions (maximum percentage of glycol 30%), non-corrosive fluids.

Production range: from Ø 16 to Ø 32 mm, different configurations (straight, curved, T-shaped etc.) and with different types of connections (female threaded connections, male threaded connections, intermediate press connections).

1650 Series

Press fitting for "AL-COBRAPEX" multilayer pipe, made up of: CW617N brass body, PA ring nut / dielectric and viewer ring, EPDM O-ring seal, clamping bush in AISI 304 stainless steel, ISO 7/1 (EN 10226) threads.

Maximum working temperature: + 95 °C. Minimum working temperature: - 20 °C (provided the fluid remains in the liquid phase). Maximum working pressure: 10 bar (relative to the AL-COBRAPEX multilayer pipe).

Fluid compatibility: drinking water, water and glycol solutions (maximum percentage of glycol 30%), non-corrosive fluids.

Production range: from Ø 14 to Ø 90 mm, different configurations (straight, curved, T-shaped etc.) and with different types of connections (female threaded connections, male threaded connections, intermediate press connections).

1650CTSN Series

Compact press fitting for "AL-COBRAPEX" multilayer pipe, made up of: CW617N tin-plated brass body, PA ring nut / dielectric and viewer ring, EPDM O-ring seal, clamping bush in AISI 304 stainless steel, ISO 228 / ISO 7/1 (EN 10226) threads.

Maximum working temperature: + 95 °C. Minimum working temperature: - 20 °C (provided the fluid remains in the liquid phase). Maximum working pressure: 10 bar (relative to the AL-COBRAPEX multilayer pipe).

Fluid compatibility: drinking water, water and glycol solutions (maximum percentage of glycol 30%), non-corrosive fluids.

Production range: from Ø 16 to Ø 32 mm, different configurations (straight, curved, T-shaped etc.) and with different types of connections (female threaded connections, male threaded connections, intermediate press connections).

1650SN series

Press fitting for "AL-COBRAPEX" multilayer pipe, made up of: tin-plated CW617N brass body, PA ring nut / dielectric and viewer ring, EPDM O-ring seal, clamping bush in AISI 304 stainless steel, ISO 7/1 (EN 10226) threads.

Maximum working temperature: + 95 °C. Minimum working temperature: - 20 °C (provided the fluid remains in the liquid phase). Maximum working pressure: 10 bar (relative to the AL-COBRAPEX multilayer pipe).

Fluid compatibility: drinking water, water and glycol solutions (maximum percentage of glycol 30%), non-corrosive fluids.

Production range: from Ø 14 to Ø 63 mm, different configurations (straight, curved, T-shaped etc.) and with different types of connections (female threaded connections, male threaded connections, intermediate press connections).

1650DR series

Press fitting for "AL-COBRAPEX" multilayer pipe, made up of: body in anti-dezincification CW602N brass, PA ring nut / dielectric and viewer ring, EPDM O-ring seal, clamping bush in AISI 304 stainless steel, ISO 7/1 (EN 10226) threads.

Maximum working temperature: + 95 °C. Minimum working temperature: - 20 °C (provided the fluid remains in the liquid phase). Maximum working pressure: 10 bar (relative to the AL-COBRAPEX multilayer pipe).

Fluid compatibility: drinking water, water and glycol solutions (maximum percentage of glycol 30%), non-corrosive fluids.

Production range: from Ø 14 to Ø 63 mm, different configurations (straight, curved, T-shaped etc.) and with different types of connections (female threaded connections, male threaded connections, intermediate press connections).

CERTIFICATIONS

1650 Series - 1650CT Series



1650SN Series - 1650CTSN Series



1650DR Series

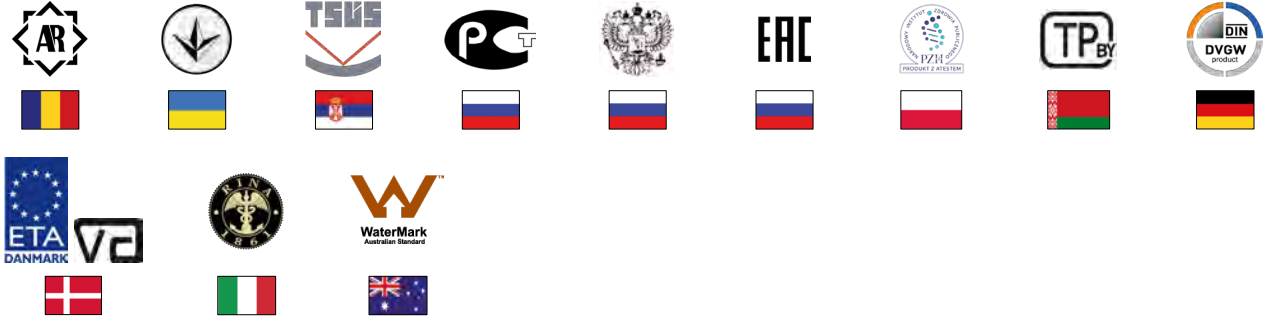

1650.W_Rev.P_04/2023 - TIEMME RACCORDERIE S.p.A. reserves the right to make changes at any time without notice. No form of reproduction is permitted, unless authorised