



# VALVOLA DI SFOGO ARIA SOLARE SOLAR AIR PURGE VALVE

## Art.1900SUN

### Descrizione / Description

Valvola di sfiato automatica per impianti solari. Disponibile in versione nichelata.

Automatic air purge valves for solar systems. Available nickel-plated.

### Funzione / Function

Le valvole automatiche di sfiato aria sono generalmente utilizzate negli impianti idrosanitari, negli impianti di riscaldamento o solari per eliminare l'aria rimasta intrappolata nei circuiti durante il loro riempimento oppure durante il loro normale funzionamento. In tal modo si evitano fastidiosi problemi quali rumorosità dell'impianto ed usura dei componenti garantendo un miglior rendimento degli elementi scaldanti.

The automatic air purge valves are used in water, heating systems and solar systems to vent entrapped air during the circuit filling or during the normal working. It is then possible to avoid problems like noise and wear of devices in the circuit granting a good performance of the heating elements.



### Istruzioni d'installazione

#### Installation instruction

E' sconsigliata l'installazione in posizioni non ispezionabili ed a rischio gelo. Per svuotare l'impianto dall'aria presente è sufficiente ruotare in senso antiorario il tappino di almeno un giro dalla posizione di tutto chiuso.

It is recommended to not install the valve in places not inspectionable and at risk of freezing. To vent the circuit turn the cap anticlockwise by at least one turn from closed position.

### Caratteristiche Tecniche

Temperatura max di esercizio : 180°C  
Pressione massima di esercizio : 10 bar  
Pressione massima di scarico : 4 bar  
Filettature : maschio UNI ISO 228  
Fluidi d'impiego : acqua e soluzione glicolate  
Massima percentuale di glicole : 50%

### Technical Features

Maximum working temperature : 180°C  
Maximum working pressure : 10 bar  
Maximum venting pressure : 4 bar  
Threads : male UNI ISO 228  
Medium : water and glycol solution  
Maximum percentage of glycol : 50%

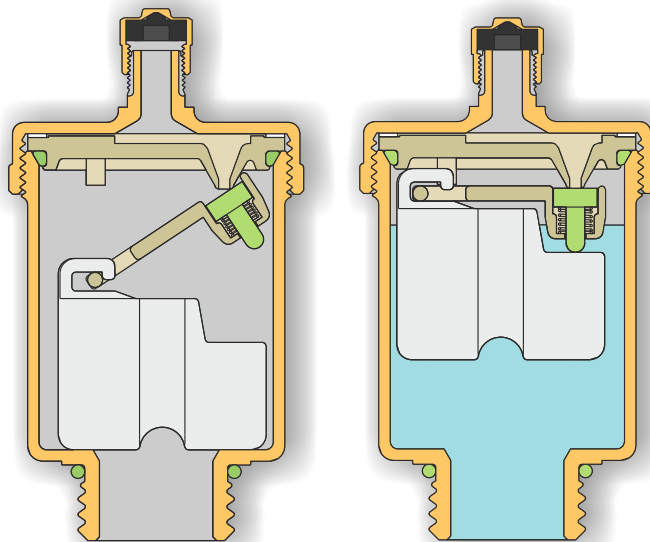

Descrizione	Materiale	Trattamento	Description	Material	Treatment
Corpo	Ottone CW617N - EN12165	Nichelato	Body	CW617N-EN12165 brass	Nickel plated
Coperchio	Ottone CW617N - EN12165	Nichelato	Cover	CW617N-EN12165 brass	Nickel plated
O-Rings	Gomma fluorurata FPM	-	O-Rings	Fluorinated rubber FPM	-
Galleggiante	Copolimero methylpentene	-	Float	Methylpentene Copolymer	-
Leveraggio	Polyphenylene oxide (PPO)	-	Other internal parts	Polyphenylene oxide (PPO)	-
Flangia	Polyphenylene oxide (PPO)	-	Shutter	Fluorinated rubber FPM	-
Otturatore	Gomma fluorurata FPM	-	Spring	Stainless steel AISI 304	-
Molla	Inox AISI 302	-	Plug	CW614N-EN12164 brass+EPDM	Nickel plated
Tappino	Ottone CW614N - EN12164+EPDM	Nichelato			

### Certificazioni/Certifications





**Dimensioni  
Dimensions**

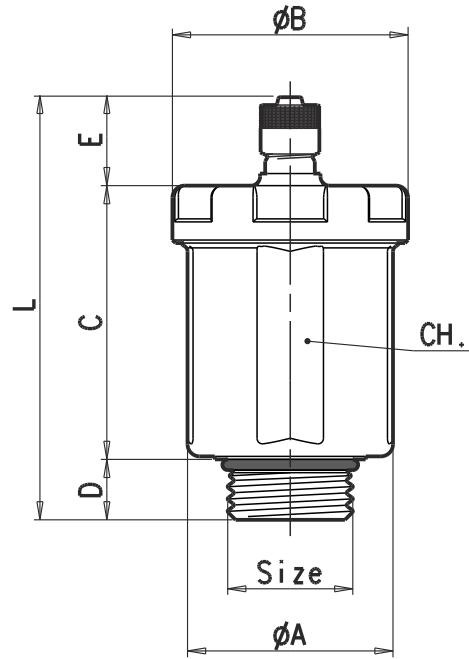

Codice Code	Size	A	B	C	D	E	L	Ch.
<b>1900N0004SUN</b>	1/2"	34	39	45,5	10	14	69,5	34



**TIEMME Raccorderie S.p.A.**  
 Via Cavallera 6/A (Loc. Barco) - 25045 Castegnato (Bs) - Italy  
 Tel +39 030 2142211 R.A. - Fax +39 030 2142206  
 info@tiemme.com - www.tiemme.com

TIEMME Raccorderie S.p.A. si riserva di apportare modifiche in qualsiasi momento senza preavviso. È vietata qualsiasi forma di riproduzione, se non autorizzata.  
 TIEMME Raccorderie S.p.A. reserves the right to modify contents in any time without prior advise. Is forbidden any reproduction unless under TIEMME authorization