



## VALVOLE PER RADIATORI TERMOSTATIZZABILI RADIATOR VALVES WITH THERMOSTATIC OPTION

### Art.3312-3313

#### Descrizione / Description

Valvola reversa termostattizzabile CON PRE-REGOLAZIONE con attacco per tubo rame, pex e multistrato (3312) o attacco per tubo ferro (3313). Fornita con cappuccio protezione cantiere

Reverse valve with thermostatic option AND PRE-SETTING for copper / pex / multilayer pipe connection (3312) or iron pipe connection (3313). Supplied with protection cap.

Le valvole della Serie 3312-3313 permettono di controllare individualmente la temperatura della stanza consentendo un evidente risparmio energetico, inoltre sono silenziose e disponibili per medie e grosse portate. Le valvole sono fornite con cappuccio protezione cantiere ma con semplici operazioni è possibile installare la testina termostatica con elemento sensibile a liquido Art. 9553. Le valvole sono disponibili anche con o-ring di tenuta sul codolo.

The valves Serie 3312-3313 individually control rooms temperature and thus save energy; have quiet operation and are fitted to the supply of radiators on two-pipe system with medium and large flow rates. The valves are supplied with protection cap but can be easily replaced with the thermostatic head built-in liquid filled sensible element Art. 9553. Valves are also available with o-ring on tail piece.



#### Caratteristiche Tecniche

Temperatura max di esercizio:	110°C
Pressione max di esercizio:	10 bar
Pressione differenziale :	Max. 1 bar Max. 0,25 bar (Raccomandata per un' operatività silenziosa)
Valore pH :	8÷9,5
Valore Kvs :	2,37
Filetto testina termostatica :	M30x1,5
Corsa di chiusura :	11,35 mm
Utilizzo :	Acqua per impianti di riscaldamento

#### Technical Features

Maximum operating temperature:	110°C
Maximum operating pressure:	10 bar
Differential pressure :	Max. 1 bar Max. 0,25 bar (Recommended for quiet operation)
pH value :	8÷9,5
Kvs value :	2,37
Thermostat thread :	M30x1,5
Closing dimension :	11,35 mm
Medium :	Heating water

#### Dimensioni Dimensions

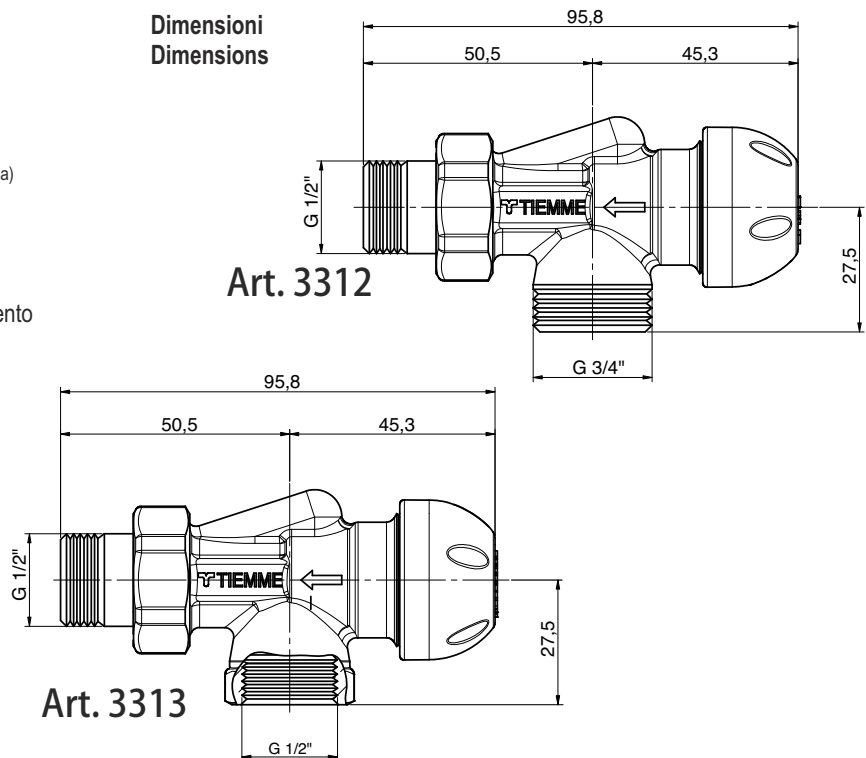

Descrizione	Materiale	Trattamento	Description	Material	Treatment
Corpo	Ottone CW617N - EN12165	Nichelato/cromato	Body	CW617N-EN12165 brass	Nickel/chrome plated
Dado e codolo	Ottone CW617N - EN12165	Nichelato/cromato	Nut and tail piece	CW617N-EN12165 brass	Nickel/chrome plated
Elemento interno	Ottone CW617N - EN12164 e guarnizioni in EPDM	-	Insert	CW617N-EN12164 brass and EPDM seat-sealing	-
Cappuccio	ABS (RAL9010)	-	Cap	ABS (RAL9010)	-
Guarnizioni	Gomma etilene-propilene EPDM	-	O-rings	Ethylene-propylene rubber EPDM	-

#### Certificazioni Certifications





Diagrammi portata/perdita di carico  
Flow/pressure drop diagrams

## Art. 3312, 3313

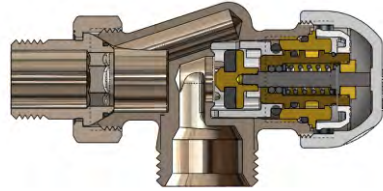

Art. 3312

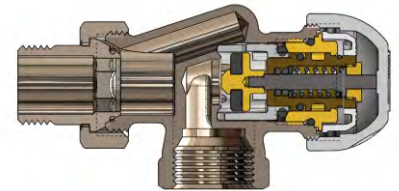
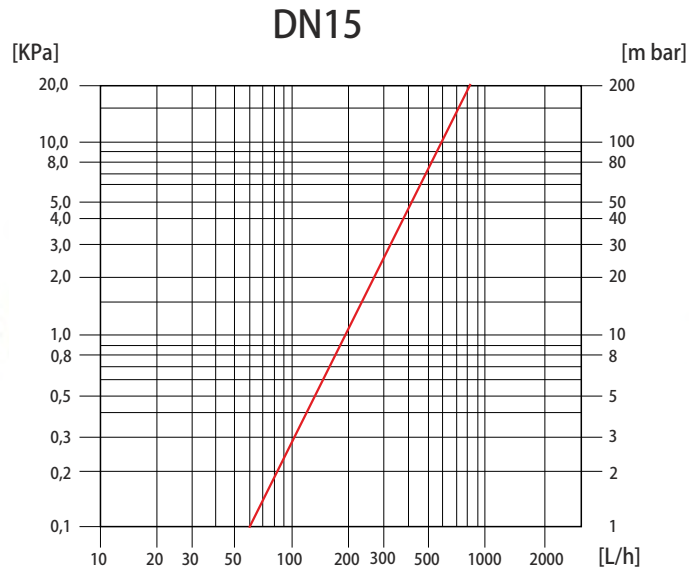

Art. 3313

### Accessori / Accessories

Art. 1241



3/4"x18

Adattatori per tubo rame con  
ogiva in rame e guarnizione incorporate  
Adaptors for copper pipe  
with built-in brass ring and gasket

Art. 1436N



3/4"x18

Adattatori per tubo Pe-x  
Adaptors for Pe-x pipe

Art. 1636N



3/4"x18

Adattatori per tubo multistrato  
Adaptors for multilayer pipe

Art. 3338



Bocchetto con guarnizione  
Tail piece with seal

Art. 3340



Rosone universale  
Universal front cover for pipe

Art. 9553



Testina termostatica  
Thermostatic head

Art. 9556



Testina termostatica  
elettronica programmabile  
Programmable electronic  
thermostatic head

**TIEMME Raccorderie S.p.A.**  
Via Cavallera 6/A (Loc. Barco) - 25045 Castegnato (Bs) - Italy  
Tel +39 030 2142211 R.A. - Fax +39 030 2142206  
info@tiemme.com - www.tiemme.com

TIEMME Raccorderie S.p.A. si riserva di apportare modifiche in qualsiasi momento senza preavviso. È vietata qualsiasi forma di riproduzione, se non autorizzata.  
TIEMME Raccorderie S.p.A. reserves the right to modify contents in any time without prior advise. Is forbidden any reproduction unless under TIEMME authorization