



CASSETTA COLLETTORI PREMONTATA ASSEMBLED MANIFOLDS BOX

Art.3035

Descrizione / Description

Collettori lineari compatti forniti montati in cassetta completi di rosoni e cappucci cromati con rubinetti di arresto a vitone.

In line compact manifolds supplied assembled on plastic box and equipped of round rings, chrome plated caps and stop cocks.

La coppia di collettori di distribuzione Art.3035 è generalmente utilizzata nelle reti di distribuzione di acqua calda e fredda. Sono costituiti da 6 vie fredde e 4 vie calde con uscite contrapposte. Qualora nell'installazione risultassero vie in eccesso basta intercettarle con i tappi in dotazione. Grazie alla loro configurazione permettono l'alimentazione in parallelo delle utenze per acqua calda e/o fredda riducendo al minimo le perdite di carico. I collettori sono prodotti in conformità alle normative in materia e sono certificati relativamente alla composizione chimica dei materiali impiegati ed a livello dimensionale.

The distribution manifolds kit Art.3035 is typically used for hot and cold water distribution. The manifolds are built with 6 ways for cold water and 4 ways for hot water directed to the opposite side. The ways that will not be used can be smuted-off by the plugs provided.

Due to the configuration they may be used to distribute cold/hot water in parallel reducing at minimum the pressure drop.

The manifolds are produced according to the relevant rules and are certified for material chemical composition and dimensional request.



Caratteristiche Tecniche

Temperatura max di esercizio: 110°C
 Temperatura min di esercizio: -20°C(*)
 Pressione max di esercizio: 10 bar
 Filettature: maschio 3/4" ISO 228 (cilindrica)
 maschio 24X19 fil. (cilindrica)

Technical Features

Maximum temperature: 110°C
 Minimum temperature: -20°C(*)
 Maximum operating pressure: 10 bar
 Threads: male 3/4" ISO 228 (parallel)
 male 24x19 fil. (parallel)

(*) purché il fluido rimanga in fase liquida / provided that the fluid remains in the liquid phase

Esempi di installazione

Installation examples

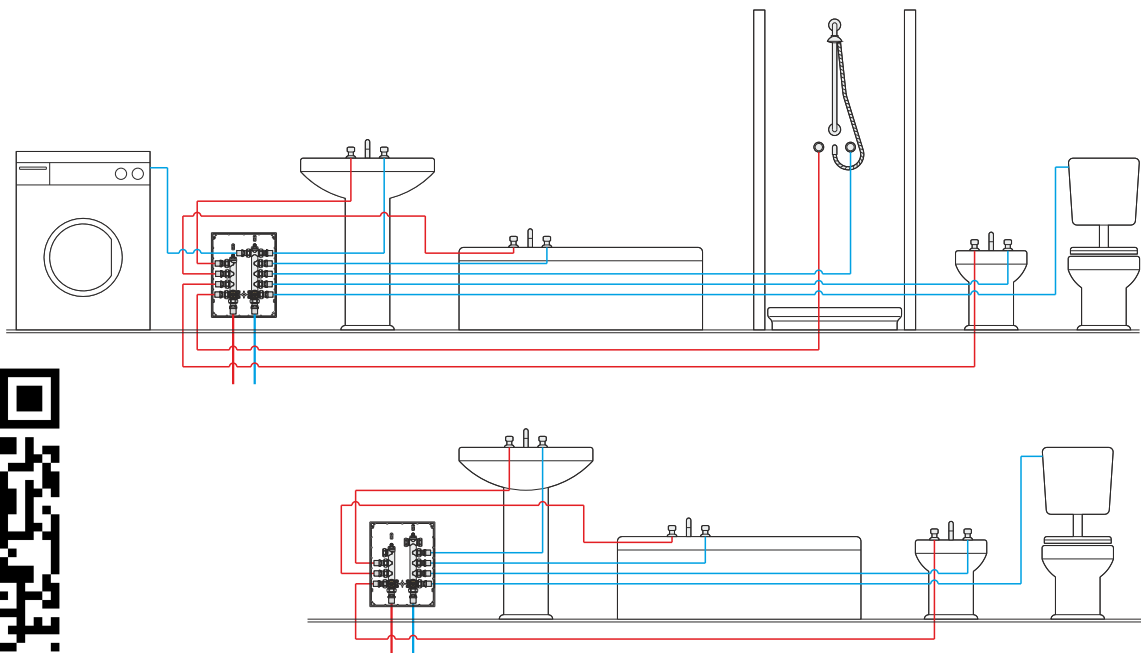

Descrizione	Materiale	Trattamento	Description	Material	Treatment
Corpi collettore	Ottone CW617N	Cromato	Manifold bodys	CW617N brass	Chrome plated
Vitoni	Ottone CW617N	-	Head screws	CW617N brass	-
O-rings	Gomma nitrilica NBR	-	O-rings	Nitrile Rubber NBR	-
Guarnizioni	Gomma nitrilica NBR	-	Washers	Nitrile Rubber NBR	-
Cappucci	Ottone CW617N	Lucidato/Cromato	Cups	CW617N brass	Polished/Chrome plated
Rosoni	Ottone CW617N	Lucidato/Cromato	Rosette	CW617N brass	Polished/Chrome plated
Cassetta	ABS bianco	-	Box	ABS white	-

Certificazioni Certifications



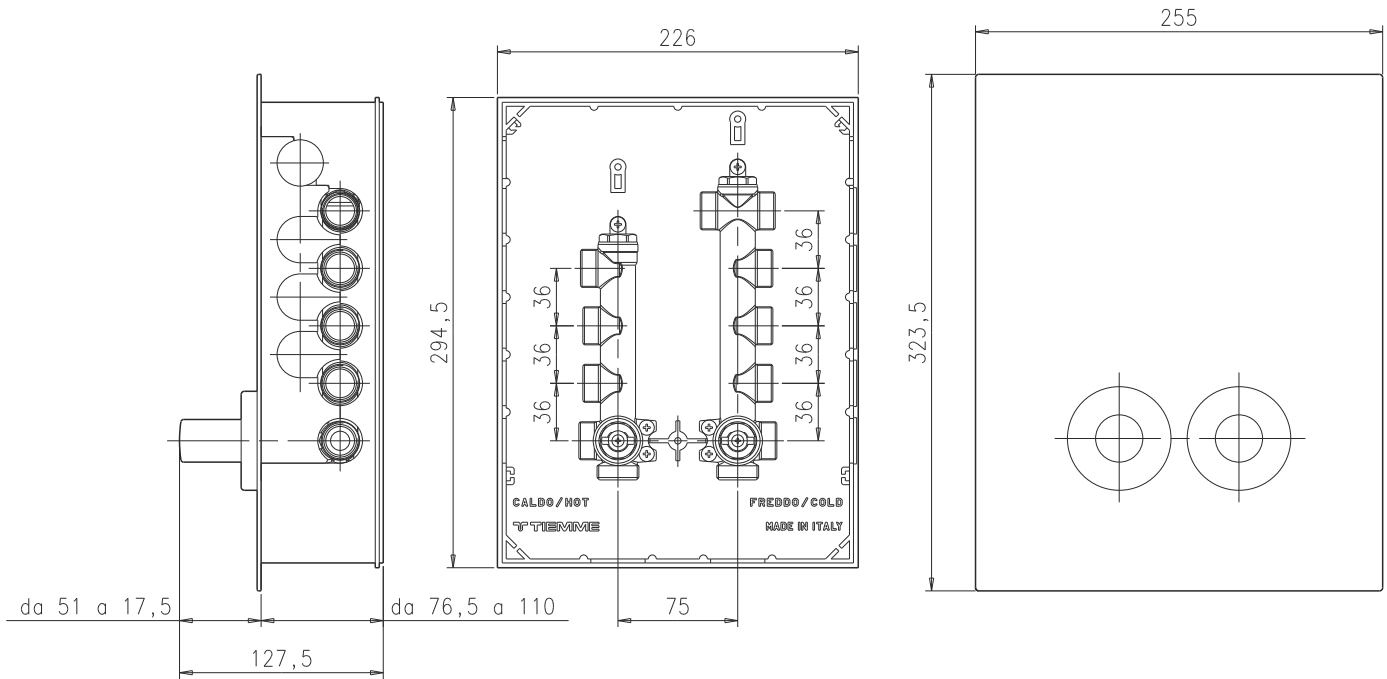

Guida alle connessioni Fitting guide

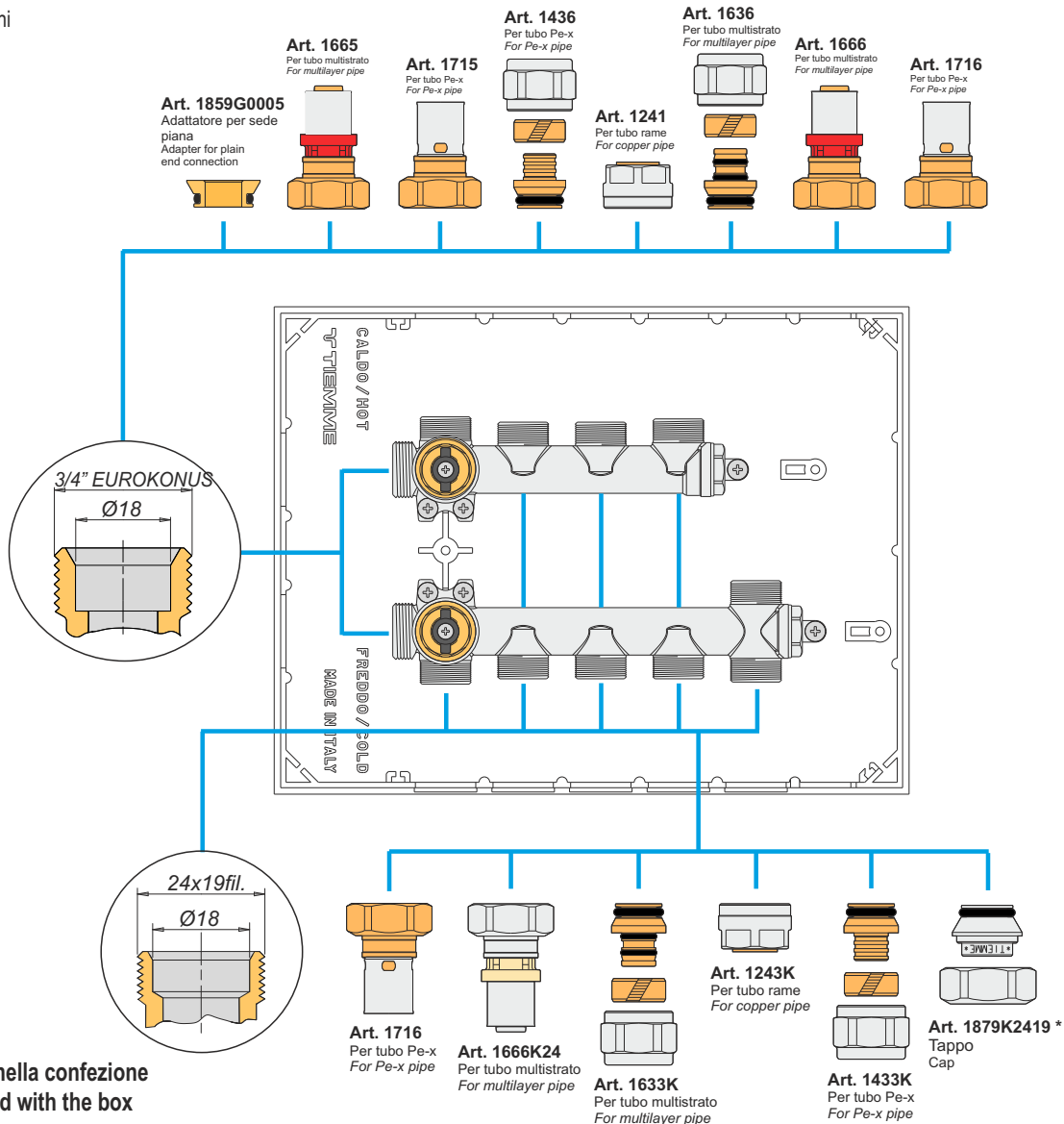

*N°3 tappi forniti nella confezione

*N°3 caps supplied with the box

TIEMME Raccorderie S.p.A.
Via Cavallera 6/A (Loc. Barco) - 25045 Castegnato (Bs) - Italy
Tel +39 030 2142211 R.A. - Fax +39 030 2142206
info@tiemme.com - www.tiemme.com